

“Tough Gear” and “High Quality” for New X-TRAIL

# 1. Evolution of genuine SUVs: New X-TRAIL e-4ORCE

Tetsuya Yamamoto\*

## 1. Introduction

In 2021, the SUV segment sold 35 million units globally, becoming the top-selling vehicle type with a 45.9% market share (Fig. 1). Since then, vehicle manufacturers have successively launched new vehicle models, significantly intensifying the competition.

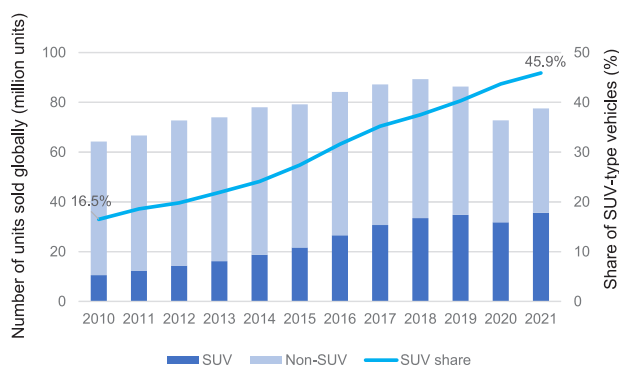

Fig. 1 Number of SUVs sold globally and share by vehicle type

Nissan has actively promoted electrification to achieve carbon neutrality and incorporated its unique e-POWER technology into the new X-TRAIL to develop convention-defying SUVs that offer and the pleasure and comfort of driving a 100% motor-driven SUV.



Fig. 2 New X-TRAIL e-4ORCE

## 2. Evolution of the new X-TRAIL

After Nissan pioneered the first-generation X-TRAIL in the middle-segment SUV market, subsequent models have inherited the powerful driving performance and highly convenient equipment that only genuine SUVs offer and have evolved by incorporating the cutting-edge technology of the time. X-TRAIL was selected by customers worldwide to travel in various environments with different road surface conditions and at different speed ranges.

The development goals for the fourth-generation X-TRAIL, which incorporate the evolved second-generation “e-POWER” × “VC-TURBO” and the electric drive four-wheel control technology “e-4ORCE,” were to evolve the rough-road drivability inherited as “Tough Gear” from the first-generation model, and realize a level of quietness and ride comfort that provide a “high quality” feeling during on-road driving, which is not possible with conventional SUVs.

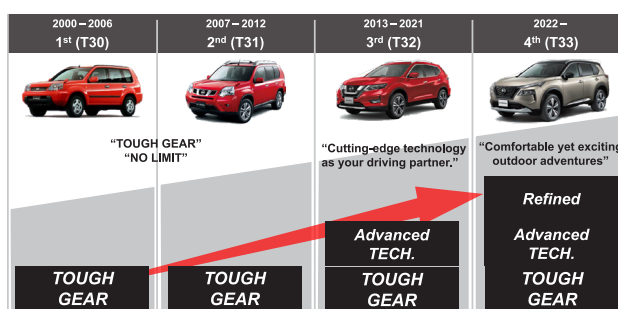

Fig. 3 Heritage and evolution of X-TRAIL

The capability to drive off-road and on snowy road surfaces provides drivers with a sense of power and security. For example, when starting from a stationary position and climbing a dirt hill with a 20% gradient (as shown in Fig. 4), a high torque is applied instantaneously to the rear tires without causing them to spin idly. This enables the vehicle to climb the hill with a speed acceleration performance 1.7 times higher than that of conventional models.

\*Product Development Department No.2

Further, driving and regenerative braking forces were controlled in units of 1/10,000 s while calculating the grip limit of each wheel. This allows the driver to operate the accelerator pedal without feeling insecure even when driving on slippery, downhill, and snowy road surfaces.

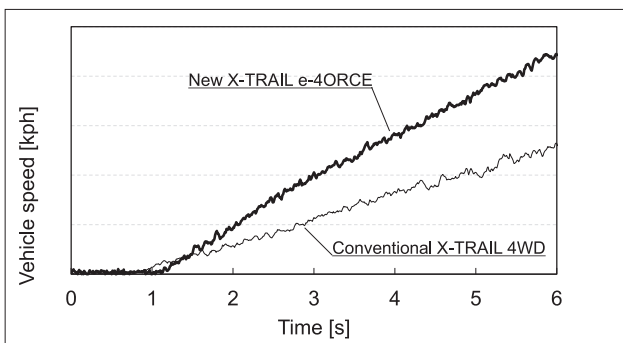

Fig. 4 Hill-start performance when climbing a dirt hill with a 20% gradient

In addition, the level of quietness and ride comfort is improved significantly, thus providing a “high quality” driving experience. The new X-TRAIL operates like an EV when driving at low speeds (e.g., in urban areas). Even when the engine generates electricity, the level of realized quietness does not allow the occupants to notice that the engine is running (Fig. 5).

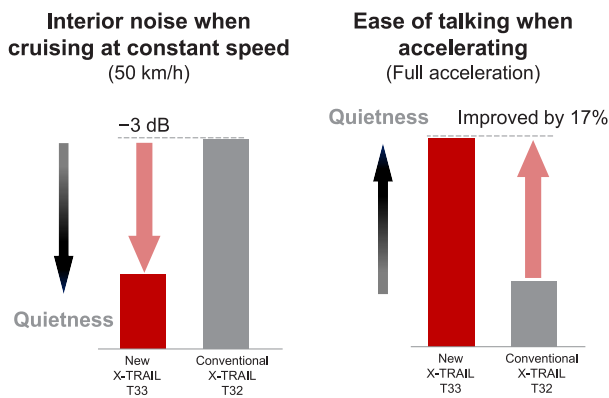

Fig. 5 Level of quietness

The sinking behavior and body motion of the vehicle during deceleration are suppressed by reforming the

suspension and using the pitching control of e-4ORCE. Thus, the occupants are less likely to feel the body motion in the front-rear direction when the vehicle is repeatedly started and stopped (e.g., driving in urban areas and in congested traffic). This helps realize a comfortable and high quality riding experience not only for the driver but also for the occupants in the passenger seat and rear seats.

The technological innovations that enabled the “Tough Gear” × “High Quality” concept of the new X-TRAIL are summarized in the following sections.

### 3. Power and high level of quietness: “e-POWER” × “VC-TURBO”

The new X-TRAIL is mounted with high-power motors at the front and rear. The variable compression ratio engine “VC-TURBO” (Fig. 6), mass-produced for the first time in the world by Nissan, is adopted as the power generation engine. This engine provides benefits such as powerful acceleration performance, low fuel consumption, and significantly improved level of quietness.

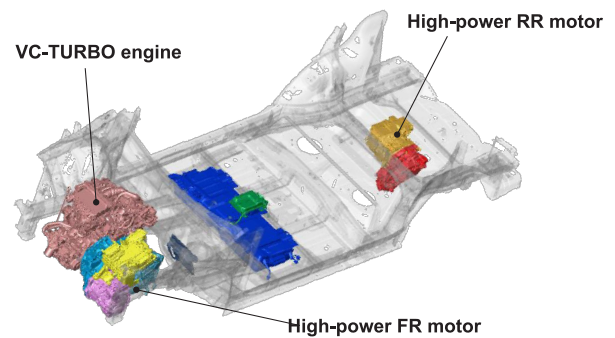

Fig. 6 Second-generation e-POWER × VC-TURBO

#### 3.1 Second-generation e-POWER

The second-generation e-POWER system incorporated in the new X-TRAIL includes high-power/high-torque front (150 kW/330 N·m) and rear motors (100 kW/195 N·m), which enable quick response and powerful acceleration performance on high-speed roads and off-road tracks. During normal cruising, low fuel consumption is achieved by optimizing the energy efficiency based on the area of frequent engine usage in the e-POWER system.

Energy management is performed by minimizing the engine starting frequency when driving at low speeds (e.g., in urban areas) and by generating electricity at low engine speeds efficiently, even when the engine needs to be started. Furthermore, the adopted control technology detects road surface conditions and starts the engine when the road noise is high, which leads to a level of quietness that can be compared to that of EVs during normal driving.

### 3.2 VC-TURBO engine for e-POWER

In the conventional e-POWER system, a high engine speed is required to obtain high power from the engine. Compared with the conventional system, the VC-TURBO engine lowers the engine speed while significantly increasing torque and power. In scenarios where low fuel consumption is required, the compression ratio is increased to generate electricity with high efficiency. In scenarios where high power is required, the compression ratio is lowered and the boost pressure is raised during electricity generation (Fig. 7). Consequently, low fuel consumption, high power, and a high level of quietness are achieved at a high level, thereby allowing a buffer when supplying electricity to the high-power motor.

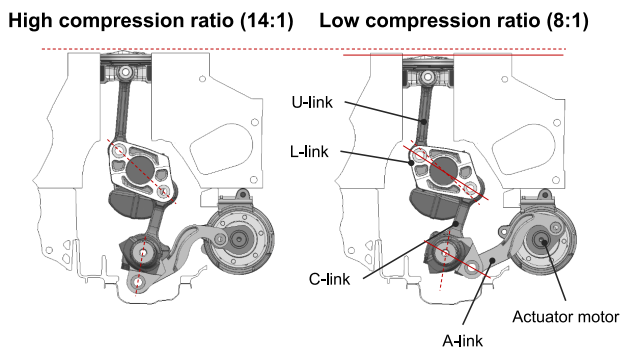

Fig. 7 VC-TURBO engine for e-POWER

### 3.3 Evolution of e-Pedal Step

The e-Pedal Step, which enables the driver to control the vehicle speed using only the accelerator pedal, employs regenerative brake/hydraulic brake integrated control for the first time in an e-POWER-incorporated vehicle to realize a stable deceleration of up to 0.2 G. The hydraulic brake is activated automatically depending on the scenario, thus enabling the driver to drive the vehicle with a sense of security and comfort in various scenarios such as urban areas (where acceleration and deceleration are repeated), long downhill roads, and snowy road surfaces.

## 4. "e-4ORCE": Changing the concept of 4WD

The electric drive four-wheel control technology "e-4ORCE" that integrates Nissan's electrification technology, 4WD control technology, and chassis control technology was mounted as a new feature. The driving force of each wheel is optimized by performing integrated control of the high-power motors (one each mounted at the front and rear) and left/right brakes. This optimization provides an exciting driving experience and a comfortable riding experience to all vehicle occupants when the vehicle is driven in various scenarios and under different road surface conditions (e.g., exerting drivability on snowy road surfaces and mountain roads and driving the vehicle for daily use in urban areas).

<Value provided by e-4ORCE>

- Easy path following as per driver's expectations: Cornering, as intended by the driver, is realized with the minimum number of steering operations by judging the road surface and vehicle conditions instantaneously and by fully utilizing the friction force of the tires by controlling the brakes and driving force of the front/rear motors precisely.
- Confidence anywhere: Smooth starting and driving experiences are realized by avoiding slipping and stuck tires and by helping to secure optimal traction, even in off-road situations and on snowy road surfaces.
- Comfortable ride for all: The oscillation of the occupant's head in the front-rear direction is mitigated when decelerating while driving in an urban area by stabilizing the vehicle body behavior via adjustments to the amount of regenerative braking applied by the front and rear motors.
- Powerful and smooth driving: A feeling of strong, sustained acceleration is realized by having high-power motors respond quickly when the driver steps on the accelerator pedal. This feature enables smooth merging with expressway traffic.



Fig. 8 e-4ORCE

## 5. High-stiffness body/chassis that supports the powerful driving performance

In the new X-TRAIL, the platform is modified completely to achieve a high level of handling stability, ride comfort, and quietness.

For the body, the usage ratio of high-tensile-strength steel sheet is increased to 42%, and a cross-frame structure that has no center tunnel or splitting portion (Fig. 9) is adopted, which increases the body torsional stiffness by 44% while suppressing the increase in mass. These new measures significantly improve the safety and dynamic performances (e.g., handling stability, ride comfort, and quietness) of the X-TRAIL.



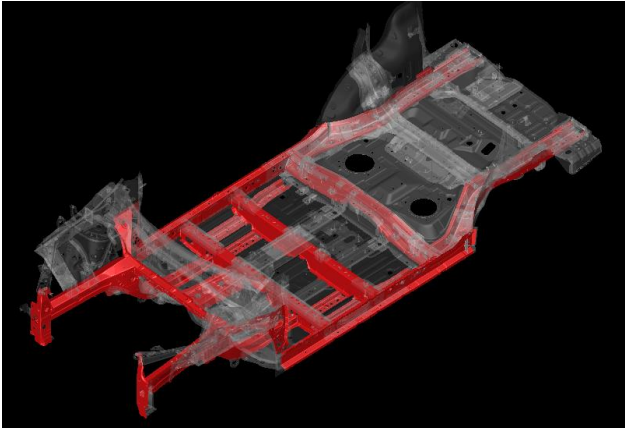

Fig. 9 Platform body

The newly designed multilink suspension, which utilizes the technology developed for the higher segment, is adopted for the rear suspension to improve stability and ride comfort (improvement in ride comfort is achieved by a 30% reduction in impact shock, which is difficult to achieve simultaneously with stability improvement). By combining these structures with a high-stiffness, quick-ratio, rack-type electric power steering system, a highly responsive handling performance requiring minimal corrective steering is realized. We hope that the drivers experience pleasurable, exhilarating, and confident driving pursued by Nissan.

## 6. Advanced and high quality interior space

The interior design of the new X-TRAIL aims to provide both toughness and high quality ride comfort (Fig. 10). The center console, designed as a bridge structure floated in the air, is provided with cup holders for large cups. Facial tissue boxes and lap blankets can be stored below the console. The console lid, which also functions as an armrest, has a double-door structure to allow stored goods to be removed from the rear seat.



Fig. 10 Cockpit

The newly developed seat material “TailorFit™” (Fig. 11) improves the smoothness because the gap between the crests of the fabric pattern are made similar to those between the crests of a fingerprint. A stable friction force and smooth touch are realized by adding particles to the top coating. Therefore, a texture comparable to that of soft leather is realized.



Fig. 11 New seat material “TailorFit™”

For the meter, a 12.3-inch advanced drive-assist display capable of selecting between two types of display modes is adopted. Further, a 10.8-inch head-up display is mounted so that the information can be displayed in an easy-to-understand manner that requires little eye movement (Fig. 12). The 12.3-inch Nissan Connect navigation system, adopted for the center display, is equipped with voice assistance and Amazon Alexa to allow occupants to perform operations using plain language. Thus, an HMI that provides various types of services while maintaining safety and convenience is realized.



Fig. 12 Head-up display

In terms of luggage space, the opening and luggage space width are widened to realize best-in-class roominess and make loading and unloading easier. A 100 VAC power supply (1500 W) outlet is provided in the luggage space. The power supply outlet can be used during outdoor activities and as an emergency power source during natural disasters. (Fig. 13).



Fig. 13 Luggage space and 100 VAC power supply

## 7. Summary

The new X-TRAIL has become a convention-defying middle-class SUV that achieves power, smoothness, and an EV-like level of quietness because of its innovative powertrain and vehicle body technology; further, it features an excellent driving performance owing to e-4ORCE. In urban areas and on winding roads, drivers can drive as comfortably as intended. On rough roads such as snowy road surfaces and off-road conditions, the drivers can drive easily with ease and a sense of security.

Nissan hopes that our customers will drive and experience our new X-TRAIL, which realizes both the “Tough Gear” × “High Quality” concept. We wish that our passion will resonate with our customers.

## Authors



Tetsuya Yamamoto

“Tough Gear” and “High Quality” for New X-TRAIL

## 2. “VC-TURBO” and “e-POWER” System

Naohiro Yoshida\* Jun Hasegawa\* Masaki Takaoka\*

### 1. Introduction

A new e-POWER system was developed and installed in the X-TRAIL for the first time to satisfy the development concepts of “Tough Gear” and “High Quality.” The purpose, outline, and system design of the e-POWER system are described in this chapter.

### 2. Overview and lineup of the e-POWER system

Fig. 1 shows the powertrain system of the e-POWER system, wherein 100% of the electric power is generated by the engine and 100% of the driving force is provided by the motor.

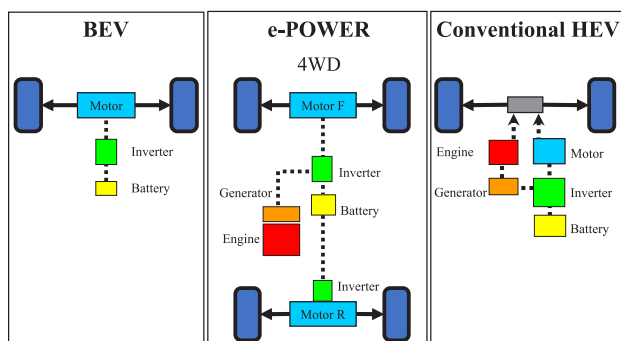

Fig. 1 e-POWER system configuration

The e-POWER system utilizes the characteristics of a 100% motor drive that generates the maximum torque at low revolutions and does not utilize a transmission mechanism. In addition, Nissan's unique motor control technology, which is created through the development of Leaf, is used to respond quickly to the accelerator pedal to ensure smooth acceleration. This is the primary feature of the e-POWER system. Further, the engine can be controlled independently of the drive system of the wheel shaft, which allows the start/stop time to be set independently of the vehicle driving pattern. Based on fixed-point engine operation, high fuel consumption

efficiency can be achieved by improving the energy efficiency once the engine is started.

In 2016, the 1<sup>st</sup>-generation e-POWER system was installed in a compact car for the Japanese domestic market for the first time. Later, in 2018, the range of models equipped with the system was expanded to include mini-vans and small Sports Utility Vehicles (SUVs) for the domestic market.

In 2020, the 2<sup>nd</sup>-generation e-POWER system was installed in a new compact car, and its most significant features—strength, smoothness, and quietness—were evolved further to create a more electric vehicle (EV)-like feeling. To this end, the motor, inverter, battery, and engine that constitute the system were improved for increasing not only the output and the torque, but also fuel efficiency. Fig. 2 shows the e-POWER lineup.

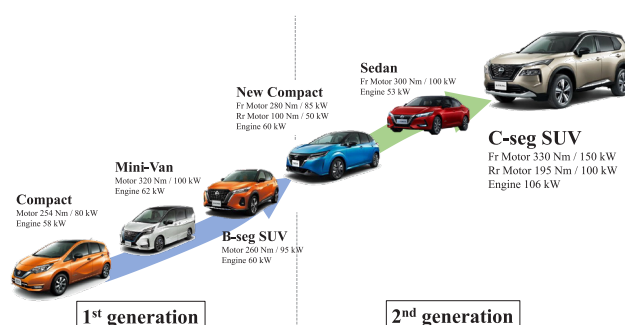

Fig. 2 Line-up of e-POWER installed vehicles

### 3. Aim of the X-TRAIL-dedicated e-POWER system

The new e-POWER system is developed as a powertrain for C-segment SUVs. It will be launched globally for the first time, with improved quietness, smoother acceleration, and increased fuel efficiency.

In recent years, the demand for C-segment SUVs has increased rapidly in the automobile market given the increase in customer requirements. To this end, the top-class levels of quietness and acceleration performance related to “EV-ness” and sufficient fuel efficiency performance need to be achieved for satisfying the

\*Powertrain and EV Engineering Division Powertrain and EV Project Management Department

high-performance requirements. Along with global expansion, the need to respond to towing requirements and high-speed driving requirements were also added.

Fig. 3 illustrates the newly developed e-POWER system and Table 1 summarizes its main specifications. Compared to the existing 2<sup>nd</sup>-generation e-POWER system, the drive motor is enlarged, the displacement of the power generation engine is increased from 1.2 L to 1.5 L with a supercharger, and the VC-TURBO engine is equipped with a variable compression ratio mechanism. Further, the 4WD model is added to the lineup.

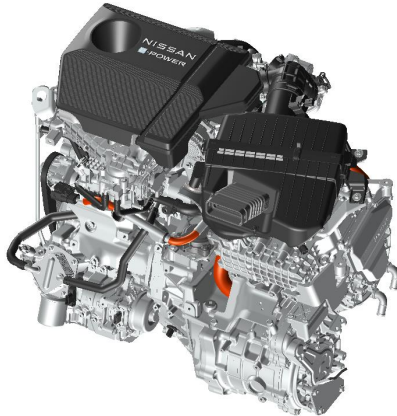

Fig. 3 New e-POWER system

Table 1 Specifications of the new e-POWER system

		Compact(2 <sup>nd</sup> gen.)	C-seg SUV
Drive system	Fr Motor power	100 kW	150 kW
	Rr Motor power	50 kW	100 kW
Generating system	Generator Power	60 kW	116 kW
	Engine type	Gasoline L3 NA	Gasoline L3 Turbo
	Engine displacement	1.2L	1.5 L
Battery	Type	Li-ion	Li-ion

#### 4. Overview of X-TRAIL-dedicated e-POWER system

The existing e-POWER system is based on fixed-point engine operation, and therefore, the fuel consumption rate during the fixed-point operation considerably affects the fuel efficiency of the vehicle. This trade-off between the fuel efficiency and the output performance needs to be eliminated to increase the engine output while maintaining fuel efficiency during fixed-point operation. To this end, the new e-POWER system employs a VC-TURBO engine to achieve high output with the compression ratio set to low at the output point, while maintaining high fuel efficiency by setting a high compression ratio during fixed-point operation. Fig. 4 shows the compression ratio map and engine operating point frequency of the VC-TURBO engine.

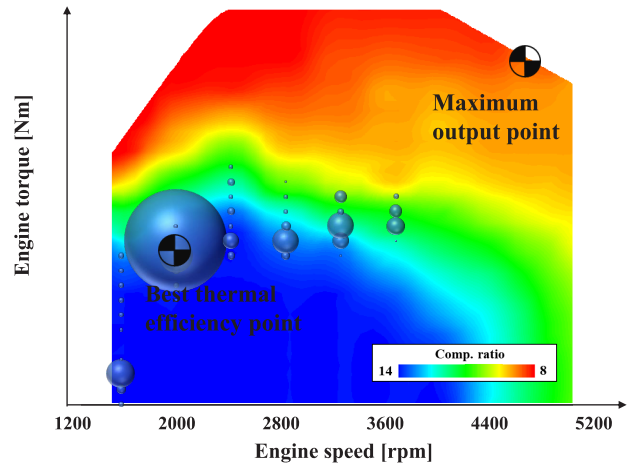

Fig. 4 VC-TURBO compression map

A special exhaust system is specifically developed for the engine operating point unique to the e-POWER system, which does not utilize engine speeds below 1500 rpm. The exhaust system reciprocates the tube in the rear muffler to reduce resonance and exhaust noise. In addition, an optimal bypass route is set to generate low exhaust pressure for ensuring sufficient engine output.

For the brake system, an electric control brake unit was incorporated in the e-POWER system for the first time; this resulted in improved quietness through collaborative control with the e-POWER system. In the previous e-POWER system, there was a need to start the engine to generate negative pressure when braking. However, the use of an electric brake eliminates this need, which reduces the frequency of starting the engine. Further, the previous e-POWER system generated a deceleration G through a regeneration system when driving downhill; however, after the vehicle is fully charged, it was necessary to maintain the deceleration G while rotating the engine at high speed and discharging the regenerative energy. The new X-TRAIL is equipped with an electric controlled brake unit that stops regeneration after a full charge and activates the electric brake to ensure deceleration G, which helps suppress an increase in engine speed and improves quietness.

#### 5. Overwhelmingly superior performance

The overwhelmingly superior quietness, acceleration performance, drivability, fuel economy, and exhaust performance provided by the X-TRAIL e-POWER system are described below.

##### 5.1 Quietness

###### 5.1.1 Engine operating frequency

The C-segment SUVs are heavier than compact cars, and therefore, the former requires more energy when starting and accelerating compared to that for the latter. Thus, the engine operating range expands if conventional energy management system is used, which can lead to an increase in the engine start frequency and a loss of



“EV-ness.”

The new e-POWER system defines the area where the driver senses the engine noise, and it is designed to prevent the engine from starting in this area to realize a quieter driving experience wherein the driver does not sense the engine starting noise.

Fig. 5 presents the above-mentioned engine operating range. The noise level inside the vehicle is evaluated. The engine startup frequency is reduced in the low speed range where the engine noise is greater than the road noise generated outside the vehicle; the frequency is increased in the high speed range where the engine noise is lower than the background noise.

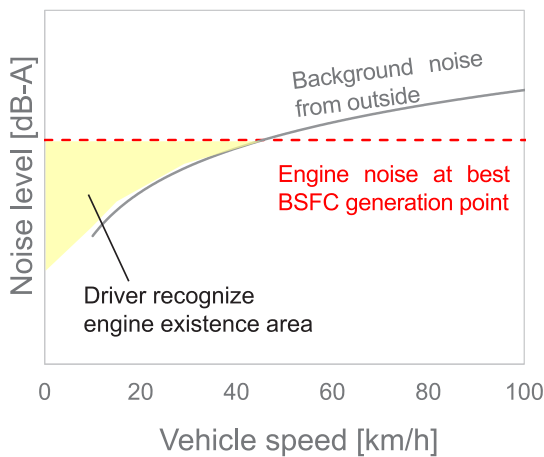

Fig. 5 Relationship between background noise and engine noise

Fig. 6 shows the frequency of engine startups at each vehicle speed in a practical driving pattern. Compared to the 2nd-generation compact car, which reduced the number of engine startups for all vehicle speed ranges, startups for the new vehicle is reduced to the 20–40 km/h range, while it is increased in the 40–60 km/h range. Therefore, it is now possible to improve quietness while increasing power generation energy.

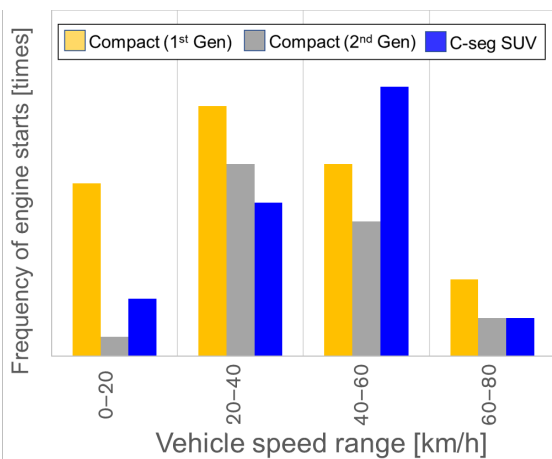

Fig. 6 Comparison of engine startup frequency

The engine is started and stopped depending on various conditions such as vehicle speed, State of Charge (SOC) of battery, and required driving force. The frequency of engine startups during one run is significantly reduced by increasing the amount of charging energy per power generation cycle at the start. Fig. 7 shows the engine operating time in the Worldwide-harmonized Light vehicle Test Cycle (WLTC) mode. The frequency of the engine startups can be considerably reduced, which helps improve quietness and fuel efficiency.

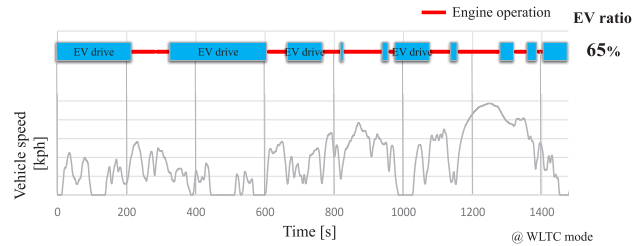

Fig. 7 Engine operation time

### 5.1.2 Lowering engine speed

Combined with the newly developed e-POWER system, the VC-TURBO engine can generate higher torque at lower revolutions than that with conventional naturally aspirated engines. This characteristic allows generating equal output at a lower engine speed compared to that with naturally aspirated engines and helps reduce the engine speed during fixed-point engine operation. Fig. 8 shows the engine speed during fixed-point operation at each vehicle speed. Compared to that for the 2nd-generation compact car, it is possible to lower the engine speed over a wide range: from low vehicle speeds with low background noise to high vehicle speeds. This facilitates reducing the engine noise level even when the engine is in operation.

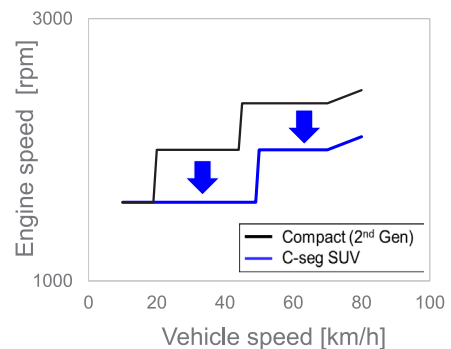

Fig. 8 Engine speed of fixed-point operation

## 5.2 Acceleration performance and drivability

### 5.2.1 Acceleration performance

The high driving power provided by the new motor of the newly developed e-POWER system and the high-output power generated by the VC-TURBO engine enable the car to achieve the top-level acceleration performance in its class.

Fig. 9 shows a comparison of acceleration G and vehicle speed profiles during the start acceleration with the conventional HEV system. The acceleration G is quickly launched immediately after starting acceleration by exploiting the 100% motor drive characteristics, which helps realize the high response. In addition, the high G is maintained to produce a feeling of acceleration growth even after the rise in acceleration G.

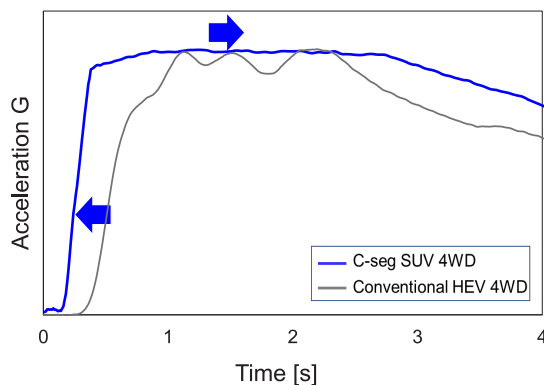

Fig. 9 Acceleration G at standing start

### 5.2.2 Drive torque control matched to supercharged engine characteristics

A supercharged engine is accompanied by a delay in the supercharging response when the torque increases compared to that for the naturally aspirated engine. Given this characteristic, the newly developed e-POWER system incorporates a new technology that controls the drive torque to ensure smooth acceleration while generating supercharging pressure.

Fig. 10 shows the relationship between the supplied energy and the generated drive torque during acceleration. The battery energy is used immediately after acceleration to generate driving torque with a good response. Meanwhile, the engine is started, and then, the energy generated by the engine is added to the energy of the battery to increase the driving torque.

The supply of the energy generated by the engine at this time is delayed because of the delay in the supercharging response. However, the drive torque is controlled to ensure a smooth increase without temporary drops attributed to this delay (a). The driving force is changed based on the acceleration request of the driver because it is possible to supply the generated energy after the engine is supercharged (b). Thus, a large acceleration is achieved compared to that of a naturally aspirated engine, whereas a smooth and boosted

supercharging pressure is generated without the uncomfortable feeling produced when the accelerator is operated.

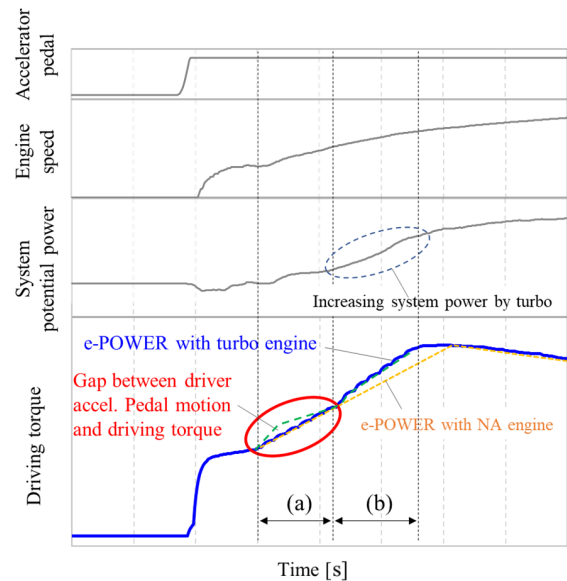

Fig. 10 Time chart of driving torque

### 5.2.3 Improved feeling of acceleration due to engine sound

We developed a technology that provides a pleasant feeling of acceleration from the sound of the engine during power generation to allow the driver to feel the acceleration not only from the acceleration G but also from the sound of the engine.

The e-POWER system can control the engine and wheel axle drive systems independently, which allows the engine speed during acceleration to be set freely. In addition, the VC-TURBO engine can generate sufficient engine torque even in the low revolution range. Utilizing these two features, the e-POWER system enables the engine speed to not only increase immediately, but also to increase in conjunction with the vehicle speed even if the driver strongly requests acceleration (when the accelerator pedal is depressed considerably).

The relationship between the engine sound (rpm) and the driver's acceleration request is defined to set the engine speed linked to the vehicle speed for the following two zones through sensory evaluation.

Zone 1, where the engine sound (rpm) is high relative to the vehicle speed.

Zone 2, where the vehicle speed and engine sound (rpm) are synchronized.

Fig. 11 shows both zones 1 and 2. In Zone 1, the engine sound (rpm) rises before the vehicle speed, which creates a sense of discomfort during acceleration. In Zone 2, the vehicle speed and engine sound (rpm) rise in tandem, which generate a comfortable feeling of acceleration that matches the acceleration request. If the driver's request for acceleration is stronger, Zone 2 can be used.

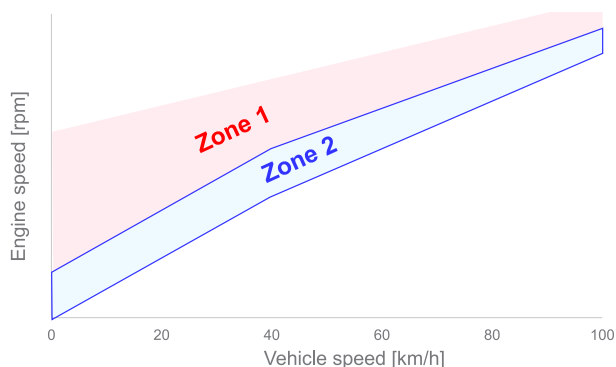

Fig. 11 Zone definition of engine sound

## References

- (1) Akihiro Shibuya, Naoki Nakada, Makoto Kimura: Development of a Brand New Hybrid Powertrain for Compact Car Market (2016)
- (2) 渋谷 彰弘 ほか: 電気駆動の魅力の拡散 日産技報 No.87 (2021)
- (3) 仲田 直樹: システムの特徴と今後の発展 日産技報 No.87 (2021)

### 5.3 Fuel consumption and exhaust performance

The engine and drive shaft are not mechanically connected in the e-POWER system, and therefore, the engine start time and the operation point after startup can be selected freely. Fuel efficiency and exhaust performance are greatly improved by exploiting this feature.

In addition to the improvement of the frequency of engine operation described in 5.1.1, the best fuel economy point of the engine is improved with the use of the VC-TURBO engine (BSFC 217 g/kWh @ 2000 rpm), which results in the top-level fuel efficiency in its class (18.4 km/L for 4WD and 19.7 km/L for 2WD in the WLTC mode). In terms of exhaust performance, a 75% reduction in emissions from the 2018 standard is also achieved.

## 6. Summary

The following technologies were developed through the development of the e-POWER system for the new X-TRAIL.

### Quietness)

Optimal control of the engine operating frequency and timing while lowering the engine speed during power generation by utilizing the characteristics of the VC-TURBO engine.

### Acceleration performance)

Drive control utilizing the newly developed motor for generating high torque and high output to allow for quick response and constant high G.

### Acceleration feeling)

Engine speed control to create an engine sound based on the driver's acceleration request and vehicle speed.

### Fuel efficiency and exhaust performance)

Optimum control of power generation at the best engine fuel efficiency point while optimizing the engine operation frequency.

Through these technologies, best in class levels of quietness, driving power, drivability, fuel efficiency, and exhaust performances in the C-segment SUVs were achieved.

## Authors



Naohiro Yoshida



Jun Hasegawa



Masaki Takaoka



## “Tough Gear” and “High Quality” for New X-TRAIL

## 3. Engine Evolution of e-POWER

Kazuhiro Ogino\*   Yoriyisa Tsuchiya\*   Hideaki Mizuno\*\*  
 Yuuki Sakai\*\*   Yasuhide Abe\*\*\*

## 1. Introduction

A 1.5 L turbo engine is developed for the new X-TRAIL to further enhance the powerful acceleration, quietness, and fuel efficiency performance features of the e-POWER system. This engine combines the world's first variable compression ratio (VCR) mechanism adopted in a mass-produced engine by Nissan in 2018 and a new low-pressure-cooled EGR (LP-EGR). The outline and features of the new KR15DDT engine installed in the new X-TRAIL are described in this chapter.

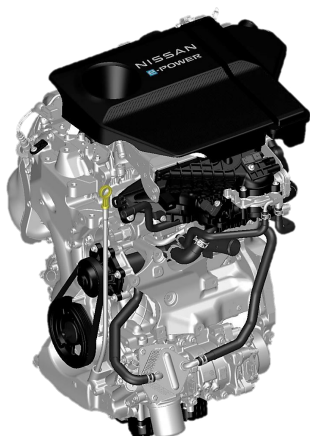

Fig. 1 New KR15DDT engine

## 2.1 Aim of engine development

The 1.2-L 3-cylinder naturally aspirated engine installed in the previous e-POWER system was improved to considerably increase the power output, quietness, and efficiency for improving the power generation energy to realize the concept of the new X-TRAIL (“Tough Gear” and “High Quality”). A 100% motor drive is attractive to achieve the high levels of quietness and smooth acceleration performance (EV-ness). To further upgrade these features, the engine was developed with the following aims.

- [1] High thermal efficiency at a fixed-point operation
- [2] High power at the maximum output point
- [3] High level of quietness
- [4] Compact engine

Fig. 2 shows the engine operating range and key performance concepts in the e-POWER system. Nissan has already succeeded in mass-producing the VCR system, and thus, it is possible to switch to a high compression ratio at [1] and to a low compression ratio at [2] using that mechanism. Moreover, it is possible to achieve both high efficiency and high output if the VCR mechanism is combined with LP-EGR.<sup>(1)</sup>

The multilink system that comprises the VCR mechanism can reduce the friction of the piston in the thrust direction. Therefore, the engine speed at the optimum fuel efficiency point can be lowered if it is combined with the improved thermal efficiency achieved by setting a high compression ratio. Further, it is possible to lower the rpm at the maximum output point by setting a low compression ratio, which helps satisfy the quietness requirement [3].

For compactness [4], the variable timing control system (VTC) is simplified for further downsizing and a 3-cylinder engine is selected. In conventional hybrid electric vehicle (HEV) engines, the compression reaction force of the engine is reduced as a vibration damping measure at engine startup. However, it is now possible to reduce the compression reaction force without the intake VTC and satisfy the relevant performance by utilizing the VCR mechanism. In addition to narrowing down the engine operating range specific to the e-POWER system, the performance-based design of variable compression and LP-EGR can achieve high efficiency, high output, and excellent exhaust performance without relying on the VTC.

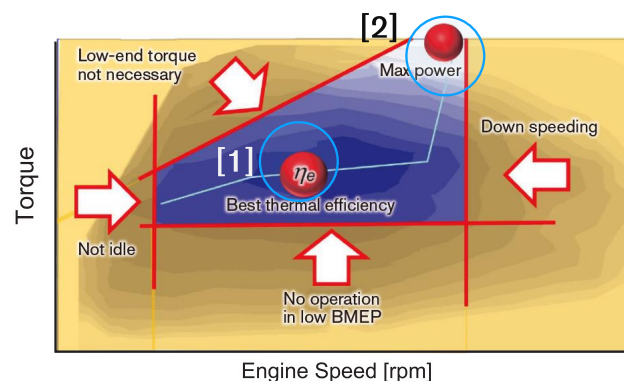

Fig. 2 Engine operating range for e-POWER system

\*Powertrain and EV Engineering Division Powertrain and EV Project Management Department

\*\*Powertrain and EV Engineering Division Powertrain and EV Mechanical system Technology Department

\*\*\*Powertrain and EV Engineering Division Powertrain and EV Performance Calibration Engineering Department

### 2.2 Working principle of variable compression ratio engine

Fig. 3 shows the configuration of the multilink system in the VCR mechanism. When the rotational posture of the control shaft changes clockwise with respect to the engine block and the eccentric axis, i.e., when the swing point of the C-link moves downward, the L-link rotates clockwise around the crankpin to enlarge the angle between the U link and L link at the top dead center; further, the U-link and piston move upward, which increases the mechanical compression ratio of the engine<sup>(1)</sup>. Conversely, changing the rotational attitude of the control shaft to counterclockwise can reduce the mechanical compression ratio. For an in-line multicylinder engine, the control shaft is shared by each cylinder, and thus, by changing the rotational posture of one control shaft relative to the cylinder block, the mechanical compression ratios of all cylinders can be switched simultaneously.

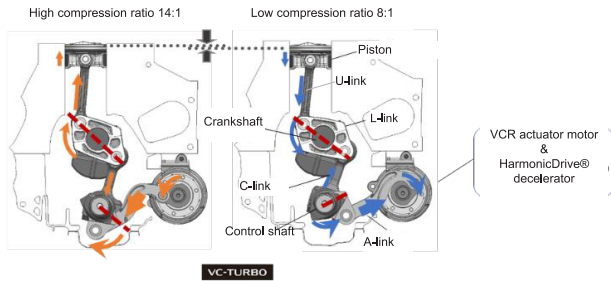

Fig. 3. Configuration of Multilink mechanism

### 3. Achieved performance

The adoption of the VC-TURBO engine greatly improved the engine torque compared to that with HR12DE engine (Fig. 4). This increases the flexibility of the engine operating point required for power generation and energy management, which in turn improves both the fixed-point operating points and quietness. Further, the generated engine noise is greatly reduced by lowering the engine speed at the maximum output point, even when the engine is under heavy load.

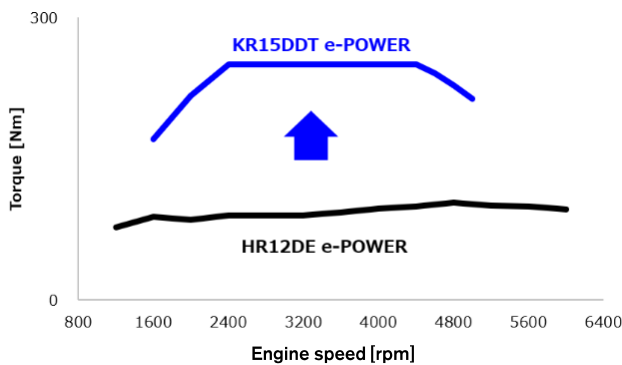

Fig. 4 Torque curve of the new engine

### 3.1 Fixed-point operation, best fuel efficiency, and quietness

Compared to the previous e-POWER HR12DE engine, the EGR rate and compression ratio (C/R) for the new e-POWER system are controlled throughout the low-load and high-load fuel consumption ranges, respectively, to improve both fuel efficiency and quietness. A transition from the quick engine start to a fixed-point operation was implemented, and performance-based design was conducted with the best thermal efficiency point at 2000 rpm (minimum brake specific fuel consumption: 217 g/kWh) as the steady-state operation point (Figs. 5 and 6).

- a) A negative-pressure-control butterfly valve was added to the EGR inlet to expand the EGR range and improve thermal efficiency by suppressing knocking under supercharging and high compression ratios.
- b) A flat piston and high tumble-intake port strengthen the gas flow in the cylinder and ensure combustion stability in the high EGR range.
- c) The multilink mechanism reduces piston thrust force, which leads to low friction.

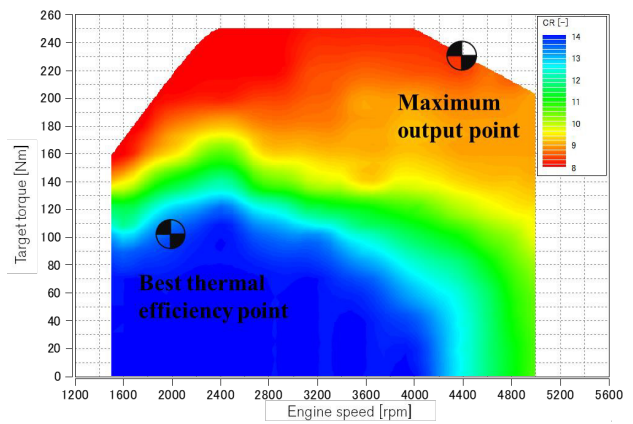

Fig. 5 Compression ratio map

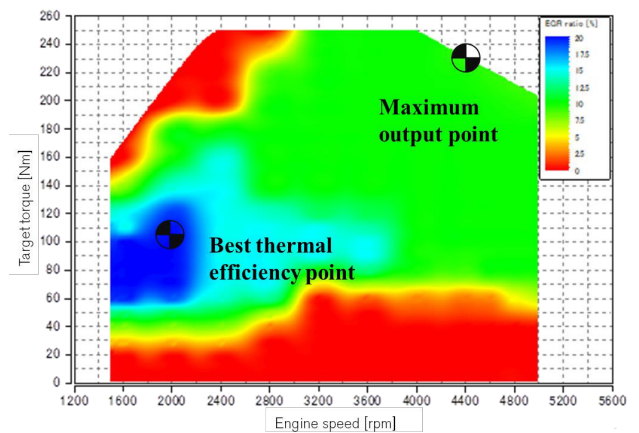

Fig. 6 EGR rate map

Conventionally, the fixed-point operation of the e-POWER system is set at around 2350 rpm to balance energy management. However, it is now possible to perform energy management at the best fuel-consumption point of engine operation through the increased options for the engine operating point attributed to the large increase in torque.

Changing the engine speed of this fixed-point operation (2350 → 2000 rpm) improves quietness considerably, which reduces engine noise by about 2 dBA. This helps eliminate the annoying engine noise while driving, which makes it possible to provide customers with the EV-ness feeling.

Now, more than 80% of the operating time can be provided in "WLTC + Extra High" mode at the best fuel efficiency point by achieving high efficiency and quietness while satisfying energy management requirements (Fig. 7).

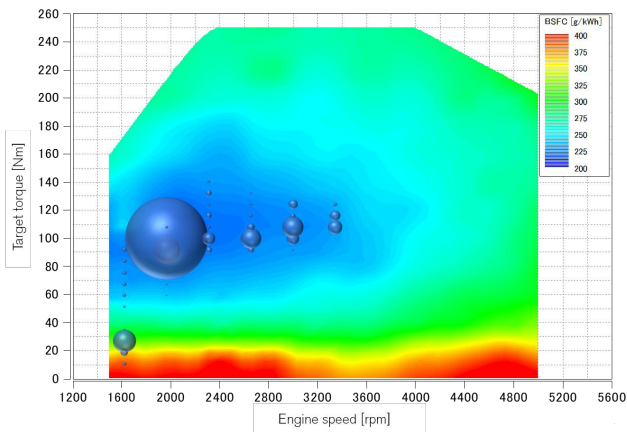

Fig. 7 Engine fuel efficiency and engine operating frequency

### 3.2 Maximum output point and quietness

The C/R of a general engine requires a design that considers the balance between fuel economy demand and output requirements. The VCR mechanism allows the C/R to be selected freely (ranging from 8.0 to 14.0) because of the VC-TURBO engine, which allows for performance-based design exclusively for the maximum output point; therefore, "C/R = 8.0" is selected. The maximum output of 106 kW is achieved at 4400 rpm (for domestic market).

This C/R setting and engine sound are compared with those of a general engine; the comparative engine setting is assumed to be C/R = 10.5. At this C/R, the maximum output point needs to be set at 5600 rpm to avoid knocking (abnormal combustion), whereas the VC-TURBO engine allows the maximum output point to be set at 4400 rpm. The engine speed can be set lower by 1200 rpm, and therefore, the engine noise is reduced by approximately 3.5 dBA under high-load conditions such as during continuous high-speed driving.

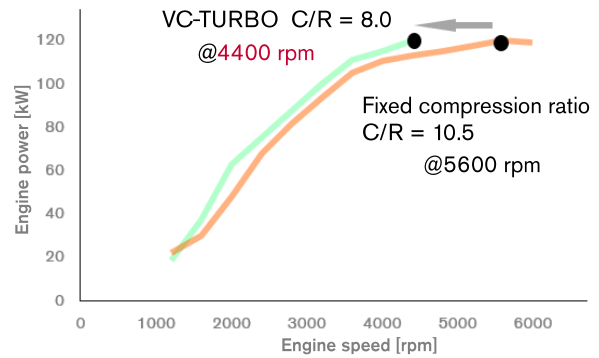

Fig. 8 Maximum output speeds at different compression ratios

### 3.3 Sound quality of 3-cylinder VC-TURBO engine

The sound pressure level of the engine at the maximum output point can be reduced considerably; however, it is not possible to completely block the engine noise from the driver. Thus, the VC-TURBO engine is designed to create a pleasant sound unlike that generated by a conventional 3-cylinder engine<sup>(3)</sup>.

In a conventional 3-cylinder engine, the main component of engine speed is the 1.5<sup>th</sup> order attributed to torque fluctuations, and therefore, the tone of the engine sound is full of low frequencies.

In contrast, the VC-TURBO engine has a high-order component in the vertical inertial excitation force of the piston because the piston motion (Fig. 9) has different ascending and descending strokes unique to the multilink mechanism.

Fig. 9 shows the waveforms of the piston's vertical inertia force of each cylinder and the graph of the resultant force at each crank angle.

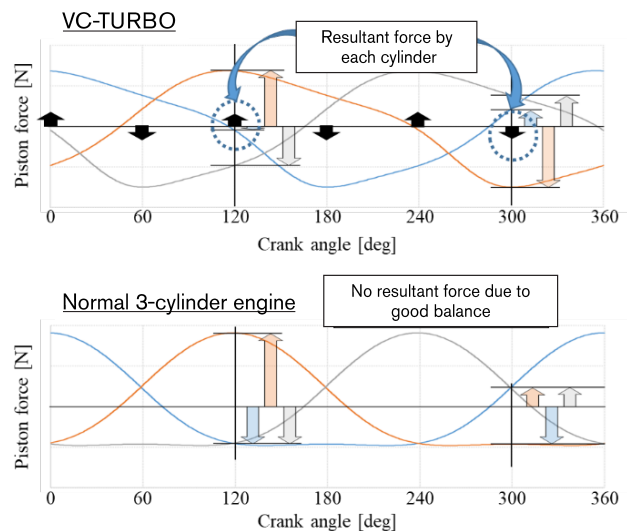

Fig. 9 Comparison of vertical piston system and piston force

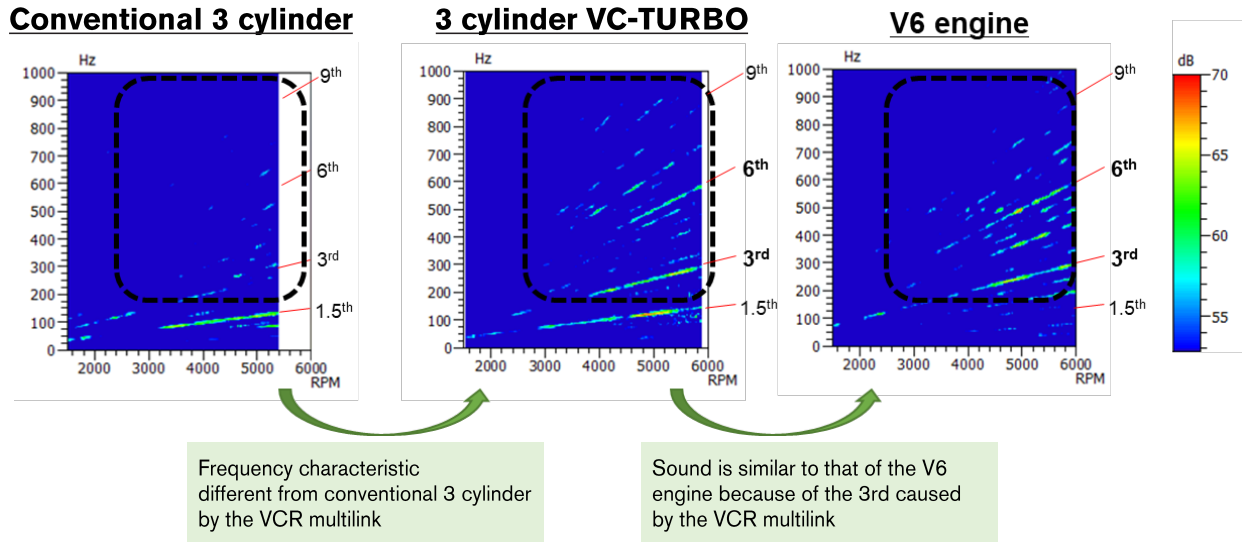

Fig. 10 Interior engine sound and frequency analysis

In a conventional 3-cylinder engine, there is no resultant force because each cylinder is balanced; in contrast, the VC-TURBO engine can generate vertical inertia force in a 120° cycle (3 cycles per engine speed). Thus, the sound heard inside the vehicle is a light sound (Fig. 10) based on the 3n-order engine speed.

#### 4. Summary

The new 3-cylinder VC-TURBO engine achieves a low rpm at the fixed-point operation and with low fuel consumption, which enables a maximum output of 106 kW at as low as 4400 rpm.

These technologies contributed greatly to achieving the goals of the new X-TRAIL performance by supporting precise power generation and energy management to realize EV-ness and quietness beyond the conventional limits.

#### References

- (1) Kiga shinichi et al.:The world's first Production VariableCompression Ratio engine -The new Nissan VC-T (Variable Compression-Turbo) engine, 38th International Vienna Motor Symposium, 2017
- (2) 松岡一哉 他: 新型 高効率1.5L 3気筒 可変圧縮比エンジン開発 自動車技術会 2021年度 秋季自動車技術会
- (3) Tsuchiya Yoriyhisu et al.:Development of the Second-Generation VC-TURBO, KR15DDT Engine, 30th Aachen Colloquium Sustainable Mobility, 2021

#### Authors



Kazuhiro Ogino



Yoriyhisu Tsuchiya



Hideaki Mizuno



Yuuki Sakai



Yasuhide Abe



## 4. Application of e-4ORCE to Full-Scale SUVs

Takeji Katakura\* Ryota Suzuki\*

### 1. Introduction

Nissan Motor plans to combine the electric powertrain system “e-POWER,” which enables 100% power generation with the engine and 100% motor-based drive, and the electric all-wheel drive (AWD) system, which incorporates two motors in the front and rear wheels, in a full-fledged SUV, New X-TRAIL (Fig. 1). The new electric AWD control technology “e-4ORCE” unveiled at the 2019 Tokyo Motor Show “ARIYA Concept” will also be applied in combination.



Fig. 1 New X-TRAIL

This chapter describes the e-4ORCE technology and AWD performance for the New X-TRAIL, which is Nissan's first full-fledged SUV equipped with an electric powertrain.

### 2. Overview of e-4ORCE

The AWD system equipped with an internal combustion engine powertrain installed in the previous X-TRAIL model was designed to mechanically distribute the power generated by the internal combustion engine to the front and rear wheels through a coupled propeller shaft (Fig. 2, left). This causes a mechanical delay in the power transmission and introduces a mechanical limit to the resolution of the distribution. Further, unlike an electric motor, the internal combustion engine has difficulty controlling the output with a high response, and it cannot control the total driving force on the order of 0.1 s.

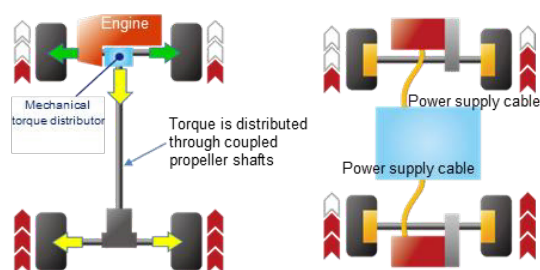

Fig. 2 Comparison of powertrain system configuration

The basic configuration of the electric powertrain “e-4ORCE” equipped with independent front and rear electric motors is shown in Fig. 2 (right). e-4ORCE enables the accurate distribution of the front and rear driving forces with high responsiveness.

One of the “e-4ORCE” control concepts is to extract 100% of the driving force of the four tires and transmit it to the road surface to stabilize the movement of the vehicle under any driving scenario. The vehicle body is supported by all four wheels, and the load applied to each wheel changes constantly depending on the road surface and vehicle conditions. Although the limit of each tire's ability to transmit the driving force to the road surface (tire grip force) (Fig. 3) changes based on the wheel load, a stable driving performance can be achieved by controlling all tires in a well-balanced manner such that they are within their limits. The new X-TRAIL e-4ORCE control function distributes the driving forces to the front and rear wheels to optimize the gripping ability of each tire based on the changes in wheel load caused by the road surface and driving conditions. Moreover, this control function controls the left and right brakes according to the driving scenario, and the braking forces are combined to improve the driving performance, except when decelerating.

\*Powertrain and EV Performance Engineering Department

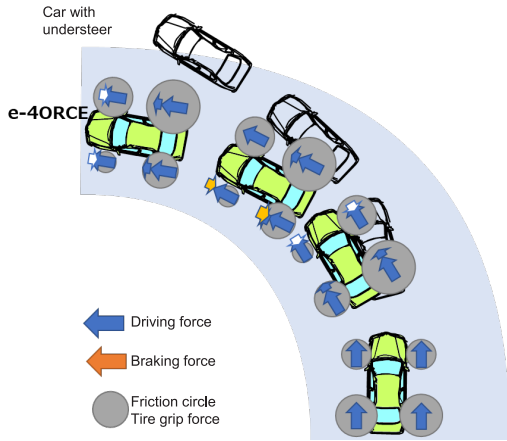
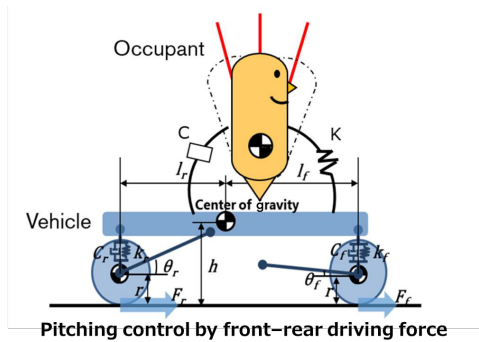

Fig. 3 Gripping ability and driving force distribution of the tire during turning

Another feature of the “e-4ORCE” control concept is vehicle pitching control, which considers the difference in the front and rear driving forces. Fig. 4 shows that the movement around the center of gravity of the vehicle shown in Equation (1) is generated according to the driving forces  $F_f$  and  $F_r$  of the front and rear tires, respectively, and the squat and dive angles ( $\theta_f$  and  $\theta_r$ ) of the front and rear suspensions, respectively. Pitching control is based on the suspension strokes generated at the front and rear tires.



$$My = l_f F_f \tan \theta_f + l_r F_r \tan \theta_r - (F_f + F_r)(h - r) - T d_f - T d_r \quad (1)$$

Fig. 4 Pitching control by front and rear driving forces

The e-4ORCE controls the difference in the regenerative braking force between the front and rear motors for suppressing changes in the vehicle attitude during regenerative deceleration (Fig. 5). Thus, the pitch behavior of the vehicle body can be optimally suppressed, and a smooth and comfortable ride can be provided not only for the driver, but also for the front and rear seat passengers. (Adopted from Note: e-Power 4WD)

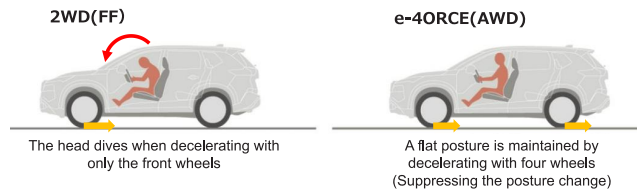

Fig. 5 Differences in car body posture attributed to pitching control

### 3. Values provided by e-4ORCE

For driver		For occupants
Easy following path as driver's expectation ドライバーの意のままの走り	Confidence anywhere 路面を問わない安心感	Comfortable ride for all 乗る人全てに快適な乗り心地
Powerful yet smooth 力強く滑らかな走り		

Fig. 6 Values provided by e-4ORCE

The values provided by e-4ORCE are shown in Fig. 6 and listed below:

- 1) Easy to follow the path as per the driver’s expectation
- 2) Comfortable ride for all passengers
- 3) Confidence to drive anywhere

Descriptions for 1) “Easy to follow the path as per the driver’s expectation” and 2) “Comfortable ride for all passengers” have already been described in section 2. This chapter describes the key value in applying e-4ORCE to the new X-TRAIL, designed as a full-fledged SUV, that is, 3) “Confidence to drive anywhere,” and it is explained from the perspective of the driver’s driving operation and how the car moves in response to the driving operation using the following two characteristic driving scenes as examples.

#### Scene 1: Deep snow start



Fig. 7 Deep snow start

As shown in Fig. 7, a routine problem encountered in parking lots in snowy areas is to start a car in deep snow after a snowfall. The characteristics of this scene are that the tires are buried in the snow and create a large amount

of resistance against the direction in which the car is moving; therefore, a large driving force (torque) is required to overcome this resistance. The frictional resistance between the snow ground surface and tire is approximately 30% less than that of a typical dry asphalt road surface, which makes the tires slip easily. Under such conditions, precise motor torque control is required to prevent the tires from slipping while providing a driving force that overcomes the running resistance. e-4ORCE can ensure a stable start with a simple accelerator operation through the coordination of optimum front and rear motor torque control and brake control based on the vertical load on the tires.

Fig. 8 compares the deep-snow starting data between the previous X-TRAIL (with ICE and mechanical AWD) and the new X-TRAIL (with e-POWER and e-4ORCE).

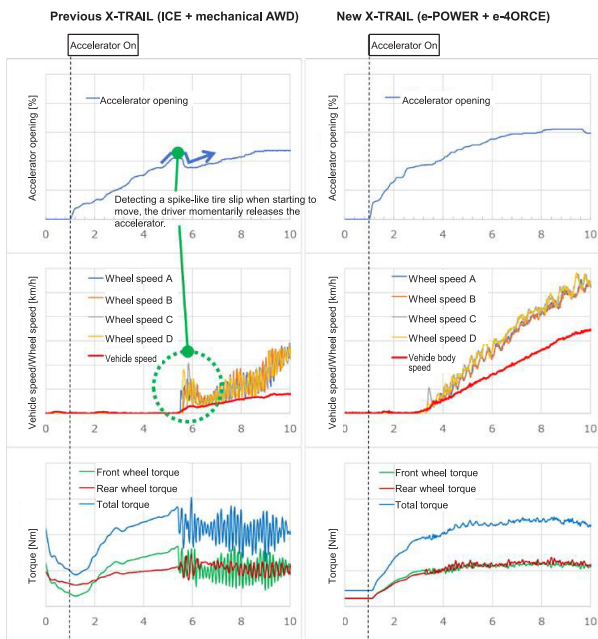

Fig. 8 Comparison of the performance when starting in deep snow

The top-row graphs show the accelerator pedal stroke, and the middle-row graphs present the correlated tire slip. In the previous model, excessive tire slip occurred as soon as the vehicle started to move and the accelerator was released. In the new e-4ORCE, which controls the amount of slip to the optimum level proportional to the increase in vehicle speed, the driver can step on the accelerator without worrying about complicated accelerator operations. For the front and rear torque comparison shown in the bottom graph, the e-4ORCE of the new model allows the front and rear torques to increase smoothly through a high torque response and through the precise control of the motor although the FF-based mechanism. The AWD of the previous model causes torque hunting because the front wheels slip.

Scene 2: Driving on mogul roads (rough surface, uneven roads)



Fig. 9 Driving on a bumpy road

Although it is unusual for a vehicle to encounter uneven terrain (bumpy roads) as shown in Fig. 9, a vehicle may encounter it at campsites, leisure facilities, off-road after bad weather, and in the event of a disaster. The characteristics of this scenario are that a large driving force is required to overcome the unevenness of the road surface, and that the running resistance of each tire changes because the vertical load condition of each tire varies depending on the unevenness of the road surface. Further, tires that have lost contact with the ground spin idly. Conventional vehicles require complicated pedal operations, such as stepping on the accelerator to apply traction each time to overcome a bump, and stepping on the brake to stop rushing after passing it. The e-4ORCE control makes use of the individual regenerative braking functions of the front and rear motor, which makes it possible to smoothly overcome the ups and downs during driving, while maintaining a constant speed simply by operating the accelerator pedal. Moreover, it allows for further reduction in the need to switch pedals because of the coordination with the brake control system that instantly suppresses the tires that have lost contact with the ground from spinning.

Fig. 10 shows a comparison of the bumpy road driving performance of the previous X-TRAIL (with ICE and mechanical AWD) and the new X-TRAIL (with e-POWER and e-4ORCE).

## 4. Conclusion

The 100% electrically driven e-POWER system and the front/rear motor AWD control system e-4ORCE installed in the new X-TRAIL achieved a high level of ease of driving operation, comfort, and sense of security in each driving scene, which is expected for SUV applications. The responsive driving, comfortable ride, and sense of security, regardless of the road surface described in this study can be experienced in a wide range of situations, from everyday use to leisure, regardless of weather, climate, and other conditions.

We hope that more customers will enjoy the new electric AWD-equipped full-scale SUV provided by Nissan.

## References

- (1) 平工 良三、ほか:特集2-成長するe-POWER\_6. 価値を高める電動AWD技術、日産技報No.87(2021)
- (2) 富樫 寛之、ほか:特集2-次世代のフラッグシップARIYA\_7. 日産が考える電動AWDの進化「e-4ORCE」、日産技報No.88(2022)
- (3) 町田 直也、ほか:ドライビングシミュレータとCAEを用いた電動AWD車加減速挙動設計手法の開発、自動車技術会2022春季大会

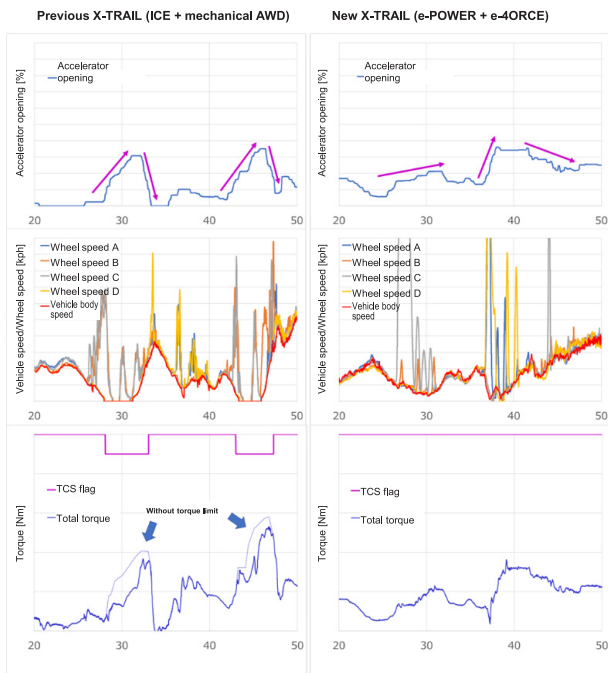

Fig. 10 Comparison of mogul road driving performance

The top-row graphs show the accelerator pedal strokes. In the previous X-TRAIL model, the accelerator pedal was turned on/off each time the car ran over uneven road surfaces. The new X-TRAIL model allows running by simply changing the amount of depression of the accelerator pedal. The bottom graphs show the tire-slip and traction control states. In the previous model (ICE + mechanical AWD), TCS (traction control) intervenes every time the tire spins to limit the engine torque; however, in the new model (e-POWER + e-4ORCE), the tire spin is appropriately controlled so that there is no need for traction control intervention. This enables continuous, powerful driving without unintended drive-force limitations.

## Authors



Takeji Katakura

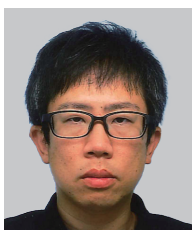

Ryota Suzuki



“Tough Gear” and “High Quality” for New X-TRAIL

## 5. NV Technology to Achieve EV-Level Quietness

Mengze Li\* Shinichi Suganuma\* Toshihisa Kuwata\* Nobunari Funatsu\*\*  
 Hiroaki Fukuoka\*\* Takefumi Mitani\*\* Kazushige Maeda\*\*  
 Yasutsune Terashima\*\*\* Yuichi Igarashi\*\*\* Kazuhisa Okada\*

### 1. Introduction

In Nissan's electrification strategy, the e-POWER system works as a sustainable technology that satisfies both environmental and driving requirements and is an important solution in addition to battery electric vehicles (BEV). Although this system has an internal combustion engine (ICE), it uses 100% electric power to drive a vehicle (Fig. 1) and can maintain the acceleration performance and quietness, which are the advantages of BEVs, while offering the convenience of not requiring charging; therefore, it is widely used.

Unlike conventional ICE-equipped vehicles, the e-POWER system switches the engine on and off without synchronizing with the driving operation of the driver; therefore, it is important to reduce the difference in noise level when the engine is switched on and off.

This section describes the evolution of quietness realization technology that enables the e-POWER system, which has been developed for compact cars, to be applied to C-segment SUVs.

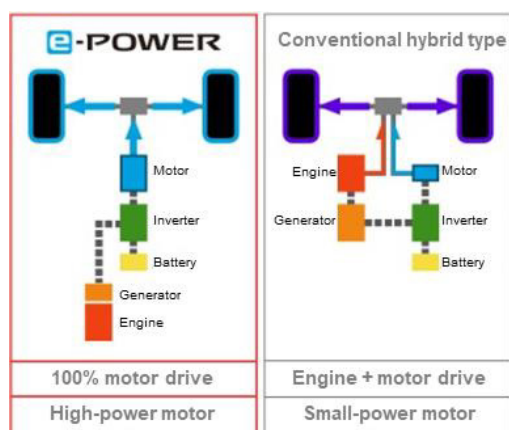

Fig. 1 Differences between e-POWER and conventional HEV systems

### 2. Challenge to higher quietness

The concepts of the new X-TRAIL include “Tough Gear” and “High Quality.” To realize quietness, which is

an important factor of “high quality,” performance development is conducted to achieve the following three points:

- (1) Reduce the frequency of engine operations (Section 3).
- (2) Quiet the engine noise (Section 4)
- (3) Match the engine sound to the driver's intention to accelerate (Section 5).

The engine used for power generation is changed to a high-output 3-cylinder downsized turbo engine to match the vehicle class of the C-segment SUV. Further, the entire vehicle, including the engine mounts, exhaust systems, active noise control, and vehicle bodies, is optimized to overcome NV-related issues such as low-frequency booming noise and vehicle body vibration.

Furthermore, the overall vehicle balance and noise insulation performance are significantly improved to ensure that customers can feel the overwhelming quietness the moment they enter or start the car. The quietness technology of the vehicles is described in Section 6.

### 3. Reducing the frequency of engine operation

Engine noise tends to stand out when background noise is low, such as when driving at low speeds. Thus, under such conditions, it is important to not operate the engine as far as possible. To this end, energy management control is implemented for actively generating power and storing it in driving scenes with high background noise. When driving at high speeds, the level of wind noise is high, which masks the engine noise and makes it less noticeable; therefore, power is actively generated. Conversely, when the vehicle speed is low (the background noise is also low), the engine is controlled so that it operates as little as possible based on the state of charge (SOC).

A road surface detection control system is adopted to control the engine start based on the road noise level to make the engine noise as inconspicuous as possible even under continuous low-speed driving conditions and to mask the engine noise with road noise.

Previous e-POWER-equipped vehicles needed to satisfy certain conditions to start the engine regardless of

\*Customer Performance & Vehicle Test Department

\*\*Chassis Engineering Department

\*\*\*Body Engineering Department

the SOC; therefore, some measures have been added to avoid engine startup requirements. There are scenarios in which the engine starts to supply negative pressure to the conventional brake system (Fig. 2); however, new brake system, electric control brake unit\*, can avoid engine operation to create negative pressure for braking.

\* Mainly adopted for Advanced driver-assistance system (ADAS) and collision safety performance, but it is also used for quietness improvement.

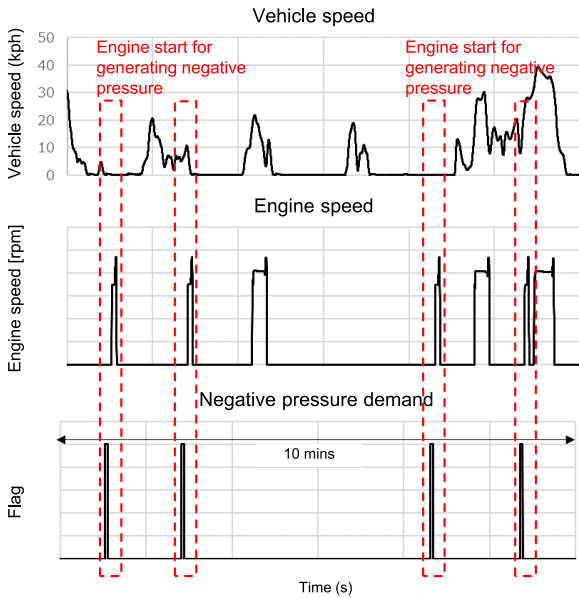

Fig. 2 Frequency of engine start for previous e-POWER system to generate negative pressure when driving in urban areas

#### 4. Quieting engine noise

If the engine starts because of a decrease in SOC in a low-load and low-vehicle-speed scenario, the engine speed is lowered compared to that of the previous e-POWER system to ensure quietness. 1.5 L VC-TURBO engine, that was already adopted with CVT, was optimized for e-POWER system. It enables operation with higher torque and efficiency at a lower speed than the 1.2 L NA engine conventionally installed in compact cars. This allowed low-noise operation while securing sufficient power generation, which helped achieve both engine noise reduction and improved fuel efficiency.

#### 5. Matching the engine sound to the driver's request for acceleration

High power must be supplied by the engine when strong acceleration is requested by the driver. However, the engine sound level needs to match the driver's request for acceleration to avoid discomfort during acceleration.

The engine sound level is highly sensitive to the rotational speed relative to the torque sensitivity (Figs. 3 and 4), and therefore, the engine speed increases linearly with the accelerator opening (acceleration G) and vehicle

speed (Fig. 5).

In addition, the electric power required for driving\* can be obtained through the characteristics of the variable compression (VC) engine by suppressing engine rotation and prioritizing torque so that the increase in rotation is considerably suppressed to provide a comfortable engine sound. For more details on 3, 4, and 5 in this chapter, refer to article 1-2. “VC-TURBO” and “e-POWER” System.

\*Power generated by the engine = torque × RPM

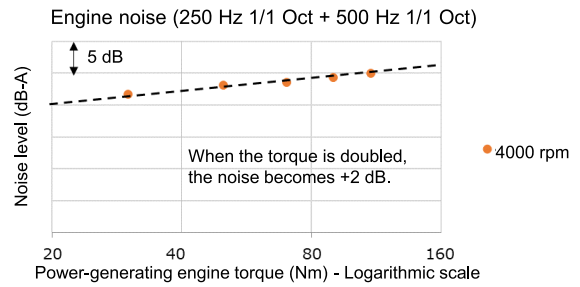

Fig. 3 Sensitivity of engine speed to engine noise

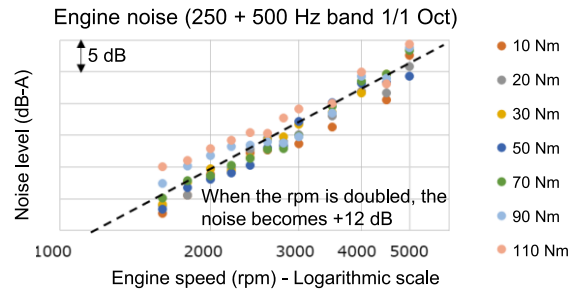

Fig. 4 Sensitivity of engine torque to engine noise

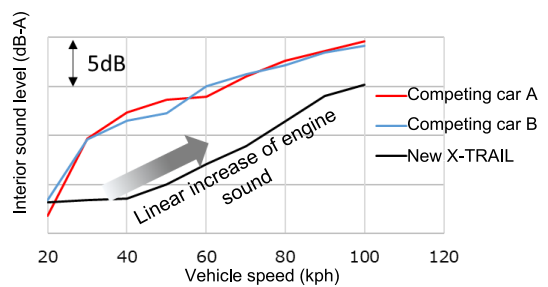

Fig. 5 Difference in engine noise at 0.2G acceleration between the new X-TRAIL e-POWER and competing cars

#### 6. Vehicle technology that supports quietness

The use of a high-torque 3-cylinder engine is advantageous for reducing engine noise caused by low rotation; however, it is disadvantageous for low-frequency phenomena such as booming noise and vehicle body vibration. Therefore, the engine mount, exhaust, active noise control, and body are improved to reduce the low-frequency sensitivity.

Moreover, high-efficiency sound insulation technology is introduced to block high-frequency engine radiation noise sufficiently to realize overwhelming quietness.

### 6.1 Engine mount

The engine mount requires component technology to achieve EV-level quietness, not to bother drivers even when the engine is running. This chapter will describe a low-stiffness pendulum mount system dedicated design for the 3-cylinder high-torque e-POWER system. Mount system is developed to ensure a small change in stiffness, up to full-throttle acceleration, and maintain a balance between an optimal mount arrangement that considers the 3-cylinder vibration mode and the engine room layout for the new X-TRAIL.

#### 6.1.1 Configuration of the mounting system

The conventional pendulum mount system is commonly used to support a lightweight, low-torque 3-cylinder engine. When the pendulum mount system handles a high-torque engine, an upper torque rod is added above the right mount to support reaction force, which will reduce input load to each mount.

For the new X-TRAIL e-POWER-dedicated mount system, the lower torque rod layout was accomplished to fit within the size of a current size torque rod by, reducing the input load and dividing the lower torque rod into a main rod and support rod. The two torque rods are placed across the nodes of the 3-cylinder engine 1<sup>st</sup> order vibration (rotational couple around the X and Z-axis of the vehicle) combined with an appropriate stiffness balance with the right-side and left-side mount. This will cancel phase of the 3-cylinder engine 1<sup>st</sup> order vibration and achieve an optimal anti-vibration engine mount design (Fig. 6).

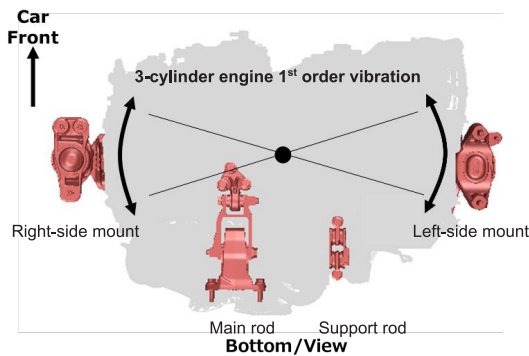

Fig. 6 Diagram of engine-mounting system

#### 6.1.2 Effect of using two lower torque rods

The use of two lower torque rods contributes not only to compatibility with the layout and 3-cylinder engine 1<sup>st</sup> order vibration but also to quietness, because it ensures low-stiffness with small change up to full-throttle acceleration.

The support rod does not have a stopper structure and rubber shape is designed to be used in a shear direction

to prevent stiffness increase when load is applied. Combining this rod to the main rod, it allows reduced input load (Fig. 7) and stiffness increase, even use of a current rod structure with a stopper function.

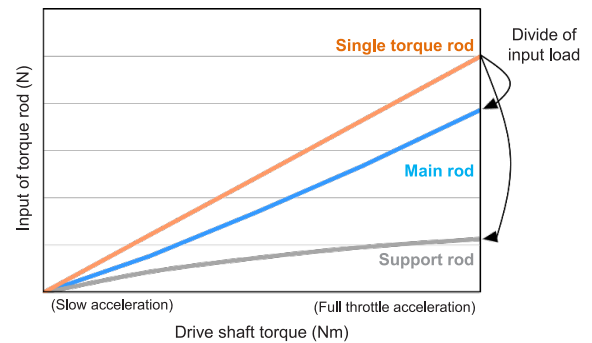

Fig. 7 Input load dividing by dual torque rods

Thus, the torque rod, which contributes to booming noise, is divided into two rods to achieve lower spring rates even at full-throttle acceleration. Low-stiffness torque rods that exhibit little change in rigidity over the entire range are used (Fig. 8).

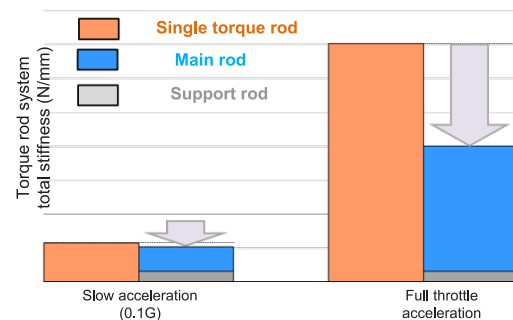

Fig. 8 Comparison of the torque rod system stiffness

### 6.2 Exhaust

In the new X-TRAIL e-POWER, the following is done to ensure vehicle quietness, especially in urban driving scenes,

- Low engine speed operation
- Engine running at high torque for power generation.

Both lower engine speed operation and higher torque increase exhaust noise. To achieve a high level of vehicle quietness during engine operation, exhaust noise reduction is required. To this end, we have developed long-flow exhaust technology that lowers the full-length resonance of the exhaust system.

#### 6.2.1 Exhaust noise reduction concept using e-POWER features

To reduce exhaust noise when the 3-cylinder high-torque engine is in operation, a large-capacity muffler is required in the center and rear of the vehicle. However,

the e-POWER is equipped with a large Battery, DC-DC converter, Fuel Tank, Rear Suspension, and Rear Bumper. So, it is difficult to install a high-capacity muffler that achieves a high level of vehicle quietness due to packaging restrictions (Fig. 9).

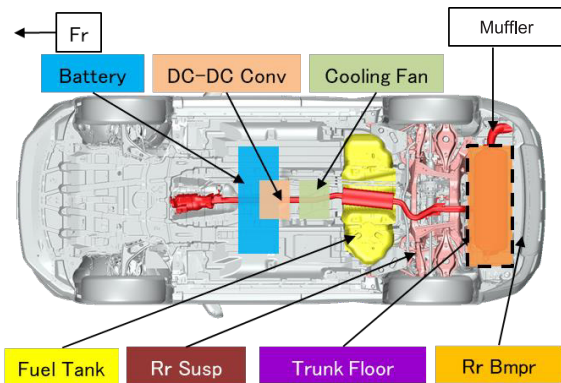

Fig. 9 Peripheral component layout

Therefore, we focused on the fact that the e-POWER does not use the idle engine speed range which is used by the ICE. The concept was to move the exhaust system full-length resonance to the idle engine speed range of the ICE. This reduces exhaust noise in the speed range which is used by the e-POWER (Fig. 10).

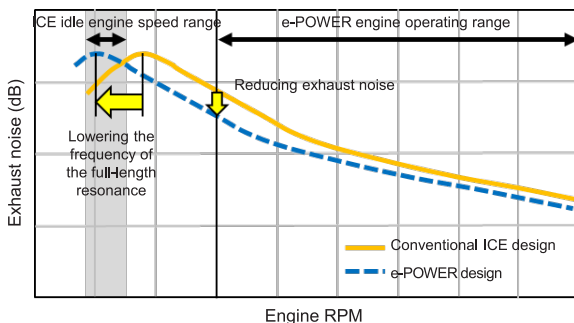

Fig. 10 Noise reduction concept of the muffler specially designed for e- POWER

### 6.2.2 Noise reduction by long flow exhaust system

To lower the frequency of full-length resonance, the exhaust gas flow path of the exhaust system was lengthened by 1.3 m compared to the conventional design of the ICE. It is most effective to lengthen the tail tube to bring the rear muffler closer to the antinode of the sound pressure in case of ensuring high silencing efficiency by extending the flow path. However, it is difficult to extend the flow path behind the rear muffler due to packaging restrictions. As a way to achieve both silencing efficiency and packaging, a long-flow exhaust system was created by reciprocating the tubes inside the rear muffler.

On the other hand, to realize a long flow system in a rear muffler, it is necessary to avoid the influence on exhaust noise caused by new resonance of the long tube.

In addition, low exhaust pressure is required to realize high torque engine. Therefore, the optimum bypass path for the e-POWER was designed to control the long tube resonance and gas flow in a rear muffler.

To this end, a long-flow exhaust system specially designed for the e-POWER that can be installed in a C-segment package that simultaneously satisfies low exhaust noise and low exhaust pressure was developed (Figs. 11 and 12).

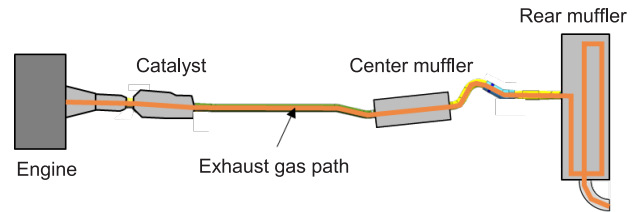

Fig. 11 Long flow exhaust system

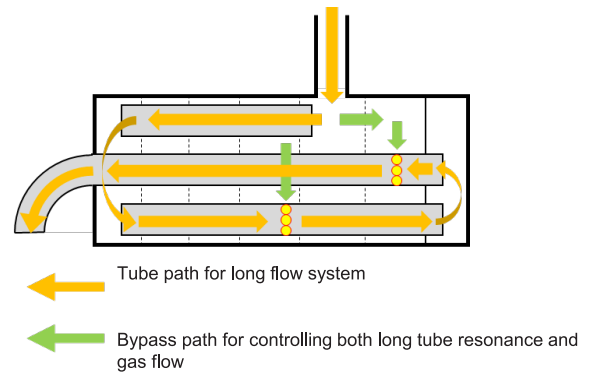

Fig. 12 Internal structure of muffler to realize long flow path

### 6.3 Active noise control

In low-load and low-vehicle speed scenes, noise reduction is achieved using the long flow exhaust path to lower the engine speed and ensure quietness. However, the necessary power generation amount needs to be secured through high-torque operation. Therefore, it is necessary to respond to the low-frequency excitation force of a 3-cylinder engine. To this end, active noise control (ANC), which is optimally suited for the VC-TURBO engine and e-POWER system, is also adopted to muffle the sound inside the car in addition to the newly developed engine mount and exhaust system.



Fig. 13 shows the booming noise reduction effect of the ANC.

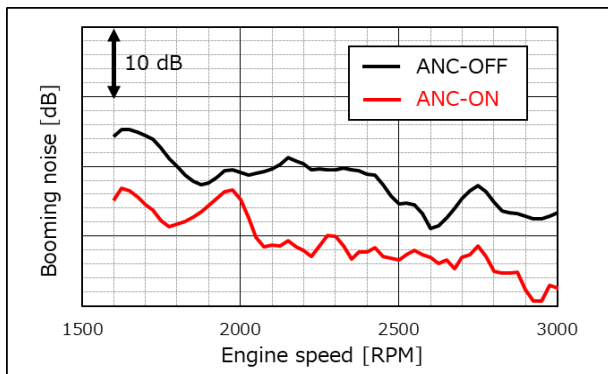

Fig. 13 Booming noise reduction effect of ANC on 1.5<sup>th</sup> order (rpm) under 0.1G acceleration

### 6.4 Low-sensitivity car body

For the new X-TRAIL, a high-rigidity, low-sensitivity body was developed to cope with the increase in the vibration level caused by the high-output 3-cylinder engine and to further improve NVH performance. A body that does not transmit noise or vibration to the users was realized by (1) reducing the eigenvalues (modes) of the body frame in the low-frequency range and (2) making the mode less likely to generate noise.

#### 6.4.1 Reduction of frame eigenvalue density

The eigenvalue of the body frame is the unique vibration mode of the body frame, such as twist and bending, and it is considered the main factor that constitutes the sound sensitivity level because it amplifies the volume change in the cabin caused by the input of the engine, suspension, etc. The car body is likely to be excited in various modes in response to various inputs (i.e., easily generating sound) if many frame eigenvalues exist in the low-frequency range (high density). Compared with the previous X-TRAIL, the new one adopts a high-output 3-cylinder engine that tends to increase the engine vibration level. Therefore, it is necessary to reduce the eigenvalue density to improve the sound sensitivity of the car body (Fig. 14).

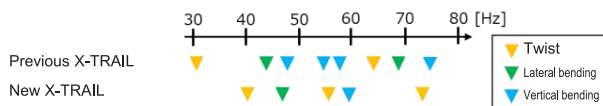

Fig. 14 Car body frame eigenvalue array table

#### 6.4.2 Improving eigenvalues (modes)

Specific measures to improve the eigenvalues (modes) and reduce the sensitivity are shown in Fig. 15. The conventional C-pillar structure uses a cross section on the outer side as a countermeasure against twist resonance, which is the first eigenvalue. The new X-TRAIL employs a circular structure (1) with a cross

section on the inner side (compression side), which contributes significantly to the rigidity and improves the eigenvalue of the frame from 30 to 40 Hz. For the lateral bending resonance of the engine compartment, which is the second eigenvalue, both the lateral rigidity and eigenvalue were improved by installing frame (2), which connects the tip of the hood ridge and the front side member. For the bending resonance in the longitudinal direction of the vehicle body, which is the third eigenvalue, the previously mentioned C-pillar inner circular structure suppresses the deformation mode in the vertical direction of the vehicle body at the rear part. Further, another circular structure (3) is provided in front of the floor tunnel to suppress the tunnel-opening mode and further increase the eigenvalue. The eigenvalue density in the low-frequency range is reduced and the sound sensitivity is significantly improved by applying these structures.

Moreover, the noise radiating panels are identified and stiffened to suppress noise radiation at eigenmode (reduce the vibration gain). For longitudinal direction dash panel vibration modes, which is one of the sounding parts, the dashed upper cross section is added to form a closed cross section (4) in the right and left directions above the dash. Further, the 7th cross member (5) is installed to connect the mounting points of the rear suspension members, which suppresses the vertical mode of the rear side members and the rear floor panel vibration mode and thus reduces the noise from the respective parts.

For other frameworks, the amount of offset from the center of the centroid is reduced, whereas the bending points of the ridgeline are minimized considering packaging restrictions. Thus, the local rigidity is improved by minimizing the seating surface of each mounting part and by increasing the rigidity efficiency. Consequently, the thickness and weight of the main frame are reduced compared to those of the previous X-TRAIL, whereas the torsional rigidity and vertical bending rigidity are increased by 44% and 40%, respectively. In this manner, a high-rigidity, low-sensitivity body that supports the high-output 3-cylinder engine of the new X-TRAIL is realized.

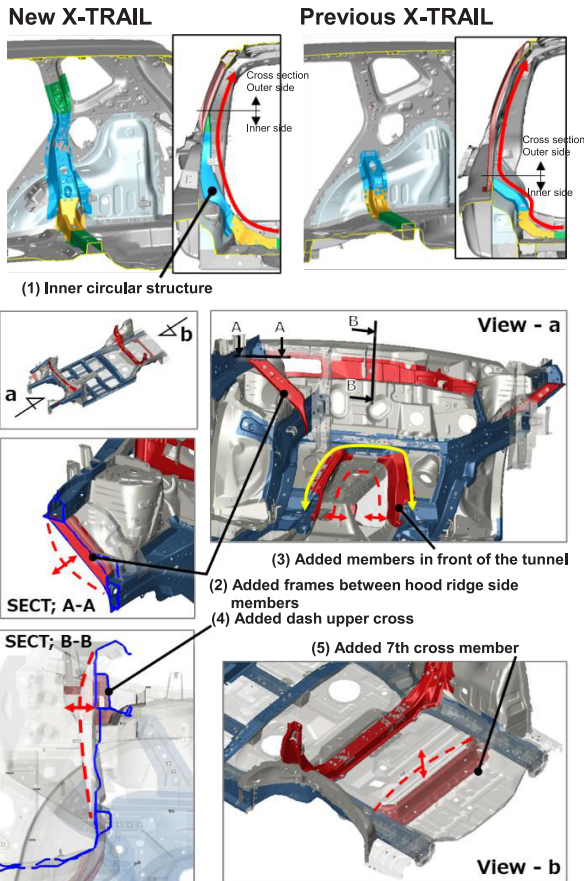

Fig. 15 Car body frame structure

The suspension is renewed (Fig. 16), and the front suspension member, which is a soft-mounted type on the previous X-TRAIL, is now a rigid type; this contributes to the high rigidity of the vehicle body. The sound sensitivity of the suspension mounting points is improved by increasing the body rigidity to maintain a low road noise level. In addition, the road noise level is improved by 1.5 dB compared to that of the previous X-TRAIL by applying softer front suspension bush and changing rear suspension member from rigid type to soft-mounted type (Fig. 17).

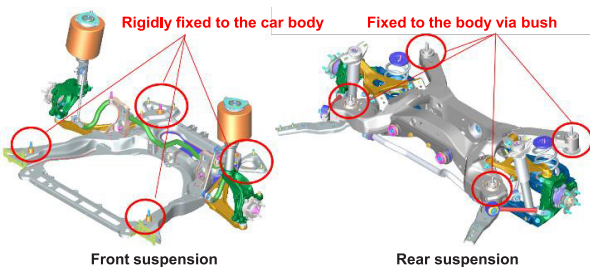

Fig. 16 Suspension structure

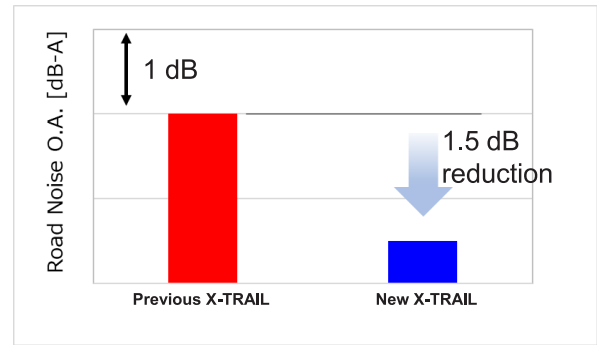

Fig. 17 Road noise level at a constant speed of 50 km/h on the rough surface road

### 6.5 Sound insulation technology

For efficiently improving the sound insulation performance, local sound leaks in the sound propagation path need to be prevented and sound insulation materials that have a double wall structure with a large distance between walls need to be used to improve the performance of individual components.

Weak points are identified on the body panel throughout the transmission path from the powertrain to the interior components, where the input contribution is high, and countermeasures based on our design policy of efficiently applying the double-wall structure are implemented.

An analysis of the existing vehicles reveals that the dash penetration and toe board contributed approximately 50% (Fig. 18). For the dash penetration part, a contribution level equal to that of the other portions is achieved by thoroughly reducing holes and gaps. For the toe board, the double-wall structure consisting of the dash panel and insulator is inherited from the existing model, and the performance is improved by 5 dB by making the insulator 157% thicker than the existing model (Fig. 19) and without adding parts or increasing the mass (B → A in Fig. 20). This contributes to a weight reduction of approximately 10 kg compared with the case where mass measures are considered instead of structural measures (C in Fig. 20).

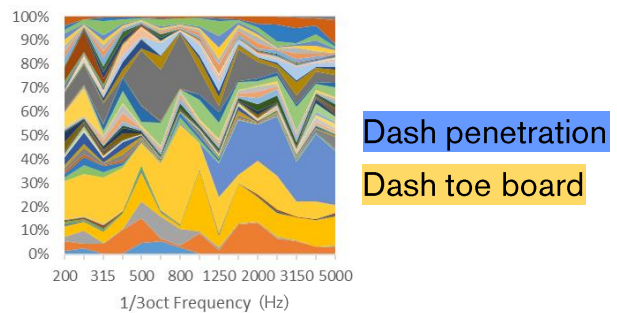

Fig. 18 Input contribution in existing vehicles

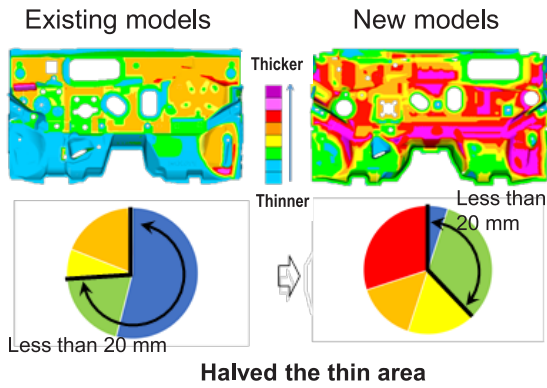

Fig. 19 Dash and insulator thickness distribution

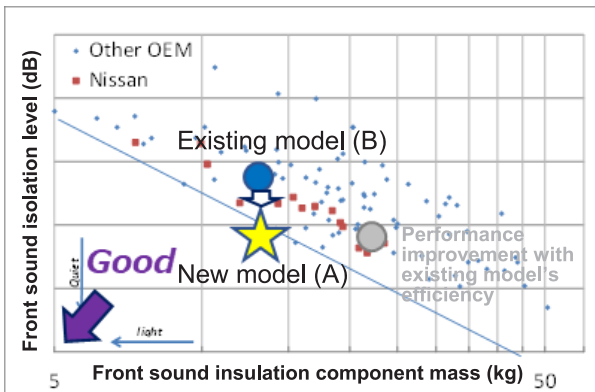

Fig. 20 Mass efficiency of front sound insulation

## 7. Summary

Nissan's original e-POWER system, which has been used mainly for small cars, has evolved with the technologies described above, and it can now support C-segment SUVs and realize powerful acceleration performance, excellent fuel efficiency, and overwhelming quietness at a high level.

We hope to continue to evolve the quietness improvement technology and contribute to society by providing more attractive electric vehicles (e-POWER, EV) to our customers.

## Authors



Mengze Li



Shinichi Suganuma



Toshihisa Kuwata



Nobunari Funatsu



Hiroaki Fukuoka



Takefumi Mitani



Kazushige Maeda



Yasutsune Terashima

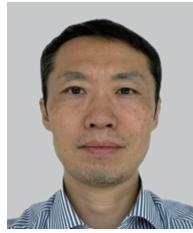

Yuichi Igarashi



Kazuhisa Okada